

Features

- 1-channel isolated barrier
- 24 V DC supply (Power Rail)
- Thermocouple, RTD, potentiometer or voltage input
- Current output 0/4 mA ... 20 mA
- Sink or source mode
- Configurable by PACTware
- Line fault (LFD) and sensor burnout detection
- Up to SIL 2 acc. to IEC 61508/IEC 61511

Function

This isolated barrier is used for intrinsic safety applications. The device converts RTD input signals or thermocouple input signals in the hazardous area to 0/4 mA ... 20mA signals in the safe area. The removable terminal block KC-CJC-** is available for thermocouples when internal cold junction compensation is desired. A fault is indicated by an LED and by user-configured fault indication outputs. If the device is operated via Power Rail, additionally a collective error message is available. The device is easily configured by the use of the PACTware configuration software.

n, refer to the manual and

Assembly

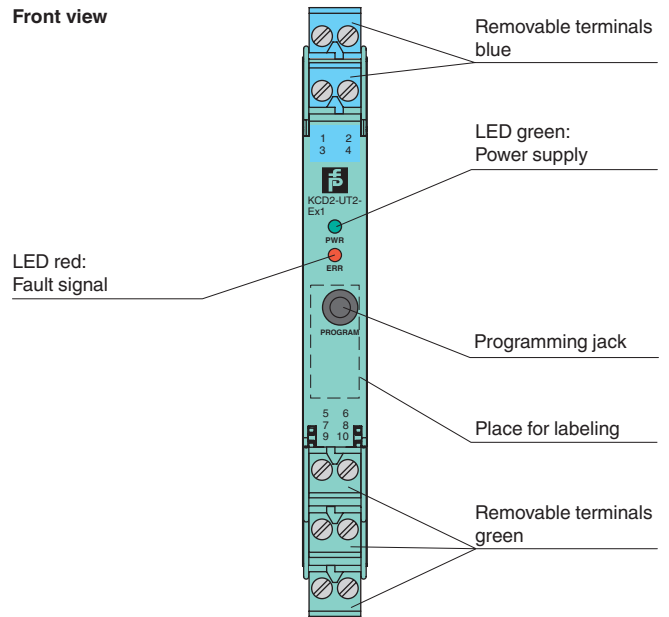

SIL 2

Connection

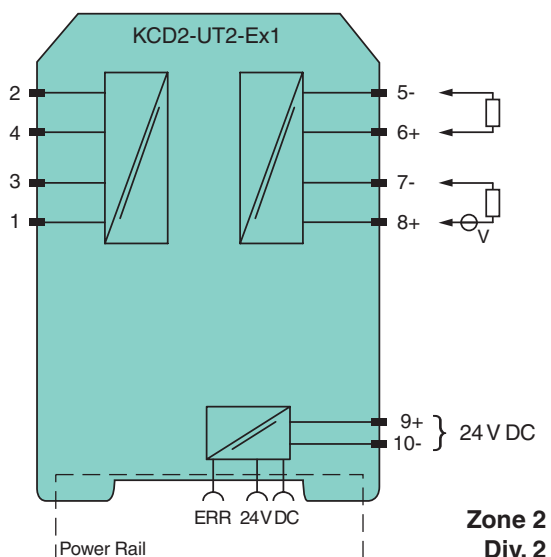
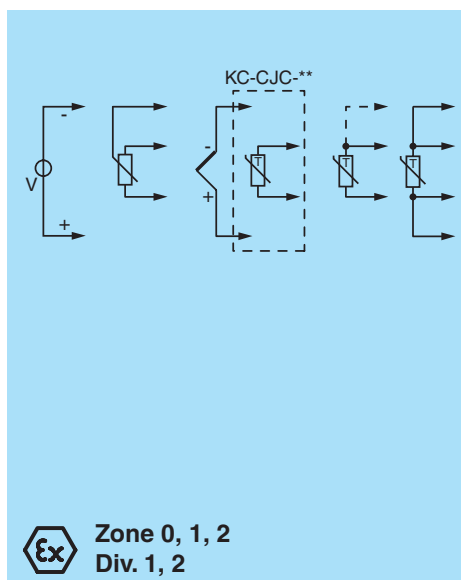

Release date 2018-02-28 08:59 Date of issue 2018-02-28 22:56:06_eng.xml

General specifications	
Signal type	Analog input
Functional safety related parameters	
Safety Integrity Level (SIL)	SIL 2
Supply	
Connection	terminals 9+, 10- or power feed module/Power Rail
Rated voltage U_r	19 ... 30 V DC
Ripple	within the supply tolerance
Power dissipation/power consumption	$\leq 0.98 \text{ W} / 0.98 \text{ W}$
Interface	
Programming interface	programming socket
Input	
Connection side	field side
Connection	terminals 1, 2, 3, 4
RTD	type Pt10, Pt50, Pt100, Pt500, Pt1000 (EN 60751: 1995) type Pt10GOST, Pt50GOST, Pt100GOST, Pt500GOST, Pt1000GOST (6651-94) type Cu10, Cu50, Cu100 (P50353-92) type Ni100 (DIN 43760)
Measuring current	approx. 200 μA with RTD
Types of measuring	2-, 3-, 4-wire connection
Lead resistance	$\leq 50 \Omega$ per line
Measurement loop monitoring	sensor breakage, sensor short-circuit
Thermocouples	type B, E, J, K, N, R, S, T (IEC 584-1: 1995) type L (DIN 43710: 1985) type TXK, TXKH, TXA (P8.585-2001)
Cold junction compensation	external and internal
Measurement loop monitoring	sensor breakage
Potentiometer	0 ... 20 k Ω (2-wire connection), 0.8 ... 20 k Ω (3-wire connection)
Voltage	selectable within the range -100 ... 100 mV
Input resistance	$\geq 1 \text{ M}\Omega$ (-100 ... 100 mV)
Output	
Connection side	control side
Connection	terminal 5: source (-), terminal 6: source (+), terminal 7: sink(-), terminal 8: sink (+)
Output	Analog current output
Current range	0 ... 20 mA or 4 ... 20 mA
Fault signal	downscale 0 or 2 mA, upscale 21.5 mA (acc. NAMUR NE43)
Source	load 0 ... 550 Ω open-circuit voltage $\leq 18 \text{ V}$
Sink	Voltage across terminals 5 ... 30 V. If the current is supplied from a source > 16.5 V, series resistance of $\geq (V - 16.5)/0.0215 \Omega$ is needed, where V is the source voltage. The maximum value of the resistance is $(V - 5)/0.0215 \Omega$.
Transfer characteristics	
Deviation	
After calibration	Pt100: $\pm (0.06 \%$ of measurement value in K + 0.1 % of span + 0.1 K (4-wire connection)) thermocouple: $\pm (0.05 \%$ of measurement value in $^{\circ}\text{C}$ + 0.1 % of span + 1.5 K (1.7 K for types R and S)) this includes $\pm 1.3 \text{ K}$ error of the cold junction compensation mV: $\pm (50 \mu\text{V} + 0.1 \%$ of span) potentiometer: $\pm (0.05 \%$ of full scale + 0.1 % of span, (excludes errors due to lead resistance))
Influence of ambient temperature	deviation of CJC included: Pt100: $\pm (0.0015 \%$ of measurement value in K + 0.006 % of span)/K $\Delta T_{\text{amb}}^{\text{*)}$ thermocouple: $\pm (0.02 \text{ K} + 0.005 \%$ of measurement value in $^{\circ}\text{C}$ + 0.006 % of span)/K $\Delta T_{\text{amb}}^{\text{*)}$ mV: $\pm (0.01 \%$ of measurement value + 0.006 % of span)/K $\Delta T_{\text{amb}}^{\text{*)}$ potentiometer: $\pm 0.006 \%$ of span/K $\Delta T_{\text{amb}}^{\text{*)}$ $\text{*) } \Delta T_{\text{amb}}$ = ambient temperature change referenced to 23 $^{\circ}\text{C}$ (296 K)
Influence of supply voltage	< 0.01 % of span
Influence of load	$\leq 0.001 \%$ of output value per 100 Ω
Reaction time	worst case value (sensor breakage and/or sensor short circuit detection enabled) mV: 1 s, thermocouples with CJC: 1.1 s, thermocouples with fixed reference temperature: 1.1 s, 3- or 4-wire RTD: 920 ms, 2-wire RTD: 800 ms, Potentiometer: 2.05 s
Galvanic isolation	
Output/supply, programming input	functional insulation, rated insulation voltage 50 V AC There is no electrical isolation between the programming input and the supply. The programming cable provides galvanic isolation so that ground loops are avoided.
Indicators/settings	
Display elements	LEDs
Configuration	via PACTware
Labeling	space for labeling at the front
Directive conformity	

Release date 2018-02-28 08:59 Date of issue 2018-02-28 225696_eng.xml

Electromagnetic compatibility		
Directive 2014/30/EU		EN 61326-1:2013 (industrial locations)
Conformity		
Electromagnetic compatibility		NE 21:2011
Degree of protection		IEC 60529:2001
Protection against electrical shock		UL 61010-1:2004
Ambient conditions		
Ambient temperature		-20 ... 60 °C (-4 ... 140 °F)
Mechanical specifications		
Degree of protection		IP20
Connection		screw terminals
Mass		approx. 100 g
Dimensions		12.5 x 114 x 124 mm (0.5 x 4.5 x 4.9 inch) , housing type A2
Mounting		on 35 mm DIN mounting rail acc. to EN 60715:2001
Data for application in connection with hazardous areas		
EU-Type Examination Certificate		BASEEFA 13 ATEX 0102 X
Marking		⊕ II (1)G [Ex ia Ga] IIC , ⊕ II (1)D [Ex ia Da] IIIC , ⊕ I (M1) [Ex ia Ma] I
Input		[Ex ia Ga] IIC, [Ex ia Da] IIIC, [Ex ia Ma] I
Inputs		terminals 1, 2, 3, 4
Voltage	U _o	9 V
Current	I _o	13.1 mA
Power	P _o	30 mW
Analog outputs, power supply, collective error		
Maximum safe voltage	U _m	250 V (Attention! This is not the rated voltage.)
Interface		
Maximum safe voltage	U _m	250 V (Attention! The rated voltage is lower.), RS 232
Certificate		BASEEFA 13 ATEX 0103 X
Marking		⊕ II 3G Ex nA II T4 Gc [device in zone 2]
Galvanic isolation		
Input/Other circuits		safe electrical isolation acc. to IEC/EN 60079-11, voltage peak value 375 V
Directive conformity		
Directive 2014/34/EU		EN 60079-0:2012+A11:2013 , EN 60079-11:2012 , EN 60079-15:2010
International approvals		
UL approval		
Control drawing		116-0379 (cULus)
IECEX approval		
Approved for		[Ex ia Ga] IIC, [Ex ia Da] IIIC, [Ex ia Ma] I
General information		
Supplementary information		Observe the certificates, declarations of conformity, instruction manuals, and manuals where applicable. For information see

Accessories

Power feed module KFD2-EB2

The power feed module is used to supply the devices with 24 V DC via the Power Rail. The fuse-protected power feed module can supply up to 150 individual devices depending on the power consumption of the devices. A galvanically isolated mechanical contact uses the Power Rail to transmit collective error messages.

Power Rail UPR-03

The Power Rail UPR-03 is a complete unit consisting of the electrical inset and an aluminium profile rail 35 mm x 15 mm. To make electrical contact, the devices are simply engaged.

Profile Rail K-DUCT with Power Rail

The profile rail K-DUCT is an aluminum profile rail with Power Rail insert and two integral cable ducts for system and field cables. Due to this assembly no additional cable guides are necessary.



Power Rail and Profile Rail must not be fed via the device terminals of the individual devices!

KC-CJC-**

This removable terminal block with integrated temperature measurement sensor is needed for internal cold junction compensation for thermocouples.

PACT^{ware}™

Device-specific drivers (DTM)

Adapter K-ADP1

Programming adapter for parameterisation via the serial RS 232 interface of a PC/Notebook

For programming, please use the new version of adapter K-ADP1 (part no. 181953, connector length 14mm). When using the previous version K-ADP1 (connector length 18 mm) the plug is exposed by approx. 3 mm. The function is not affected.

Adapter K-ADP-USB

Programming adapter for parameterisation via the serial USB interface of a PC/Notebook